



D-Flector

Stone Guards®

Installation Guide

D600

DSG045

Released Date – March 2024

D-Flector Stone Guards: Best safety companion for the road untraveled.

You have acquired a D-Flector accessories , **Congratulations**.

D-Flector stone guard provided unparallel protection to your RV, adjustable fittings, remain durable in harshest outback conditions.

Important:

1. Refer to your fitting instructions to ensure that product is installed correctly.
2. Check the contents of kit before commencing fitment and report any discrepancies.
3. Keep checking D-Flector website to ensure you have latest revisions of these instructions.

Fit Time : 30 mins



Part list:

Item No	Qty	Part Description	Image
Tube Set D600			
01	1 each	Tube Lower Front RH & LH - 58/59	
02	1 each	Tube Support Front Upper RH & LH - 65/66	
03	2	Tube Lower Rear - 67	
04	2	Tube Middle Rear Support - 68	
05	1 each	Tube Upper Rear RH & LH - 69/70	









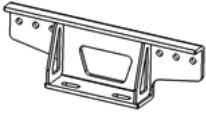
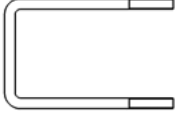
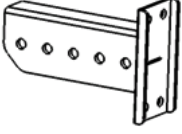
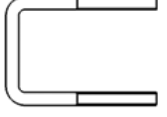

PERIODICALLY CHECK TO ENSURE THAT ALL FASTENERS ARE TIGHT AND ALL STRUCTUAL COMPONENTS ARE SOUND.

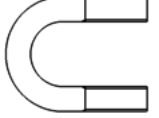
Maxwell & Higgs Pty Ltd, AUSTRALIA
 6/94-102 Keys Rd,
 Moorabbin, Vic, 3189

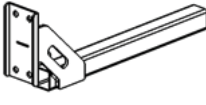
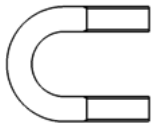
support@d-flector.com.au
www.d-flector.com.au
www.youtube.com/watch?v=xBX4PjLa79E

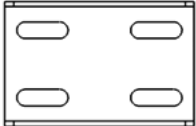
Part list:

Item No	Qty	Part Description	Image	Item No	Qty	Part Description	Image
HWK001 (Front Hardware Kit)							
11	1	Front Mounting Bracket Adjustable Assy -BKT008		15	1	U Bolt M12(50T) x 100(W) x 180(L) - UBT001	
12	1 each	Bracket Front mount OTR RH & LH Sub Assy - BKT005/BKT006		16	1	U Bolt (alternative) M12(75T) x 77(W) x 130(L) - UBT019	
13	1	V -Tube Front Cross Brace - TBE071		17	6	U Bolt Small Round M10(25T) x 26(W) x 47(L) - UBT012	
14	2	Tube Front Cross Brace - TBE072		18	Sets	Fasteners - GAL- Nuts, Bolts,Washer, Spring Washer and SS - Bolts and nylon nuts	
HWK008 (Rear Hardware Kit)							
19	2	Rear Mounting Bracket Sub-Assy - BKT003		17	4	U Bolt Small Round M10(25T) x 26(W) x 47(L) - UBT012	
20	4	U Bolt Rear M12(140T) x 41(W) x 270(L) - UBT017		22	Sets	Fasteners - Nuts, Washer and Spring Washer	
21	2	Chassis Rear lower Mounting Plate - PLA048		23	1	Mesh RH & LH + Bungees (Qty-56 PC) - CVR045	

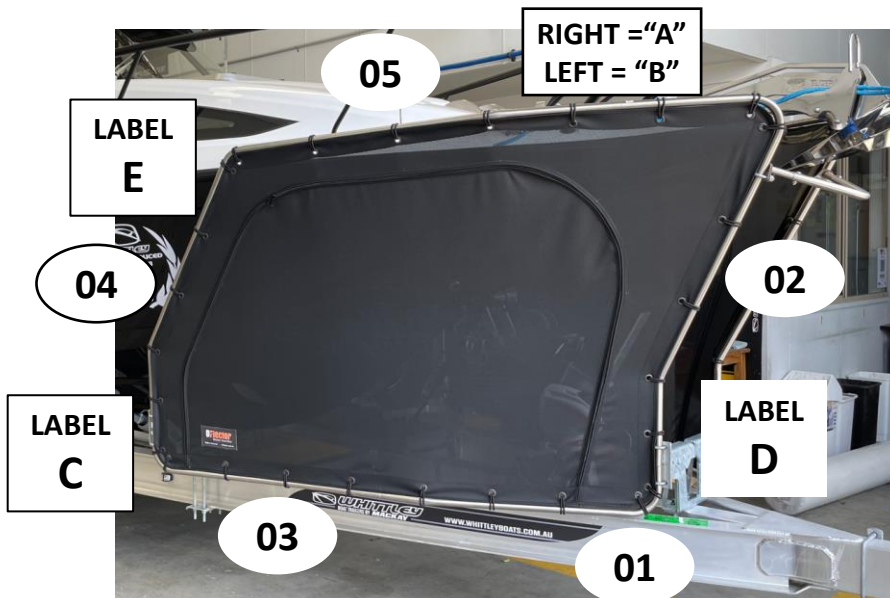

Step 1

Fit **Front Mounting Bracket Assembly (11)** to a symmetric position on the trailer drawbar using the **U Bolt (15) M12(50T) x 100(W) x 180(L)** or **U Bolt (16) M12(75T) x 77(W) x 130(L)** depending on chassis thickness.

Warning:- Ensure any cables running along or under the chassis are not interred with

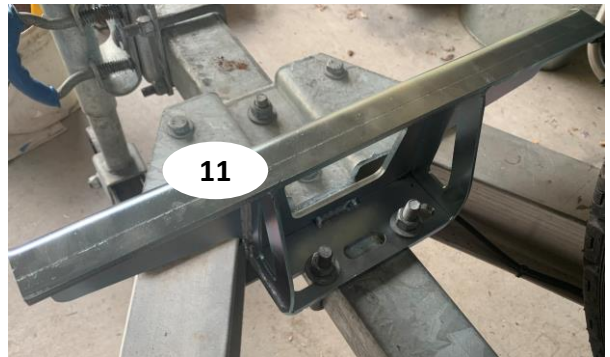

Step 2

Fit **Outer Mounting Plates Assy (12)** to each end of the **Front Mounting Bracket Assy (11)** using the **M12 x 25 Bolts, Spring Washer and nuts (18)**. Do tighten at this stage, but these may need adjusting in or out during the assembly process.

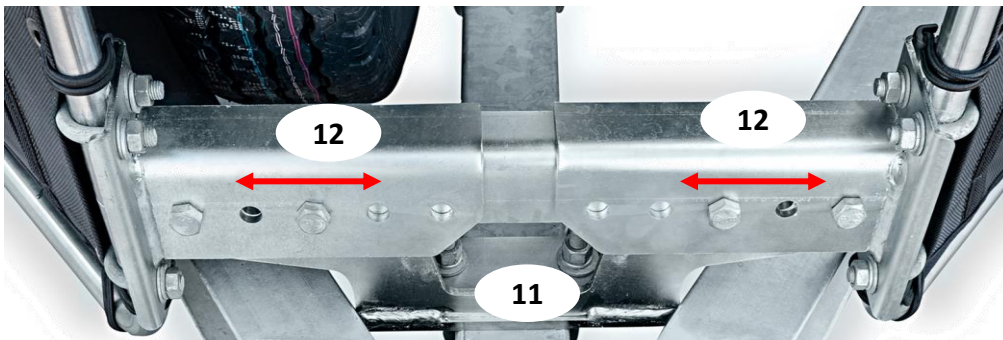

Step 3

Fit **Rear Mounting Square Tube Assembly (19)** to trailer chassis using the **two square U bolt (20) M12(140T) x 41(W) x 270(L)** and **Lower Mounting Plate (21)**.

Warning:- Ensure any cables running along or under the chassis are not interred with

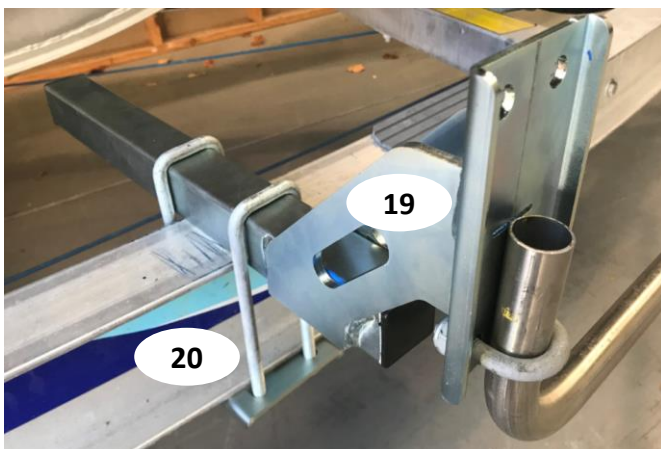

Step 3

Make sure that a **Rear Mounting square Tube assembly (19)** position is at equal distance from **front**, so that at both side of the Boat chassis, Stone guard will remain symmetric.

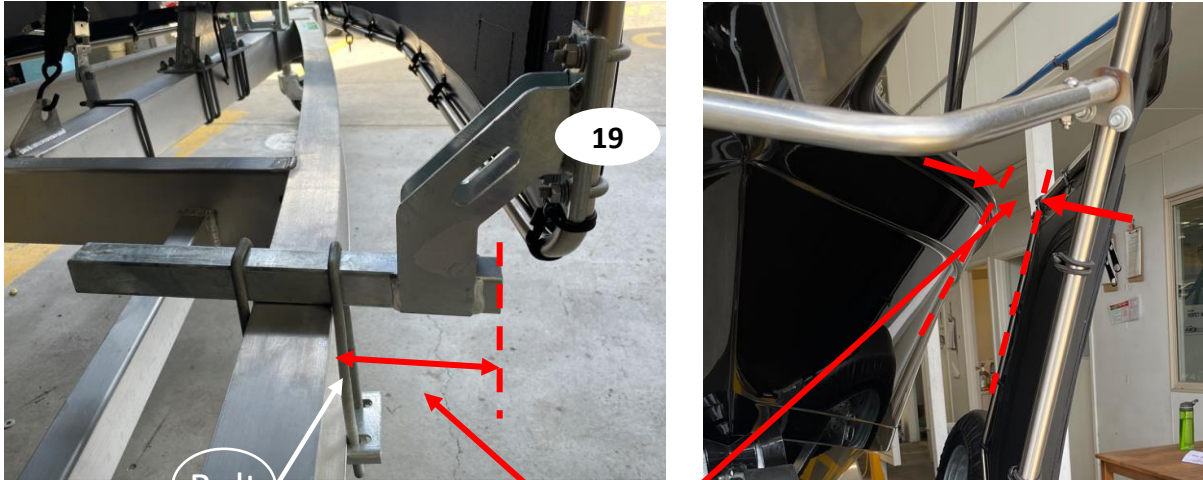

Keep appropriate and same gap on left- and right-hand side of chassis to keep minimum 100mm gap between Gunnel and upper Rear end of the Stone Guard.

Step 4

Fit **Front Lower Tube (01)** (LABELS "D") to **Front Mounting Bracket (12)** using the **Small round U Bolt (17)** M10(25T) x 26(W) x 47(L). Top of the tube should be positioned in line with the slot in the mounting bracket plate as shown in image.

Join by sliding the **Rear Lower Tube (03)** in the end of the **Front Lower Tube (01)**. Adjust position of **Rear Mounting Bracket Assy (19)** if required. Fit **Rear Lower Tube (03)** (LABELS "C") to **Rear Mounting Bracket Assy (19)** using the **Small round U Bolt (17)** M10(25T) x 26(W) x 47(L).

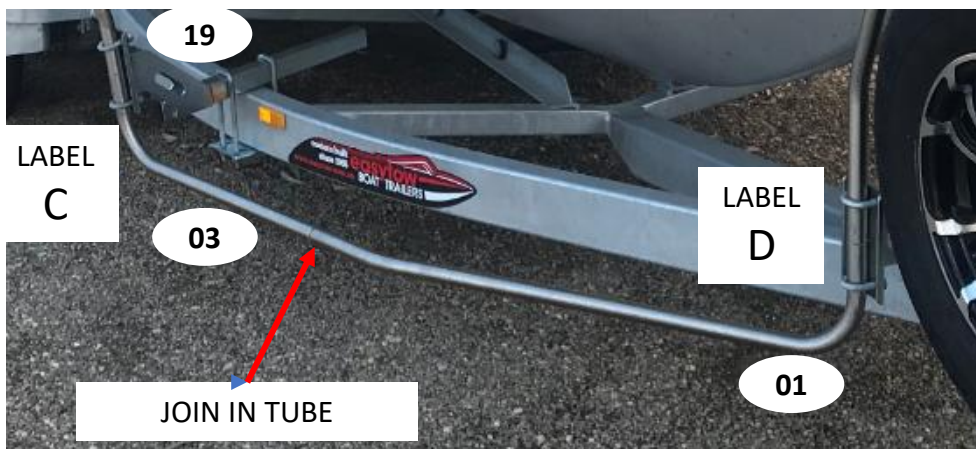

Slot alignment with Top of the Tube

Step 5

Slide the **Front Support Tube upper RH (02)** into the end of the **Lower Tube (01)** and secure to **Front Mounting Bracket (12)** with a **Small Round U Bolt (17)** M10(25T) x 26(W) x 47(L).

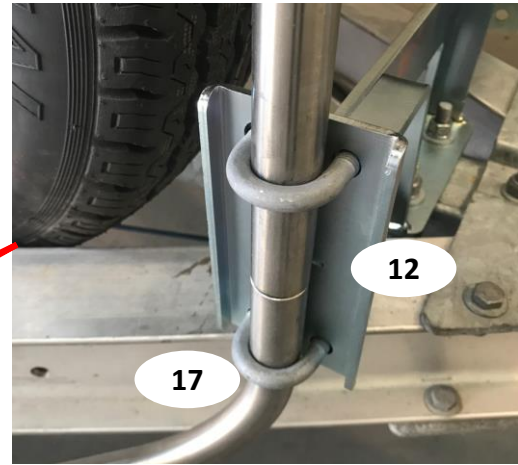
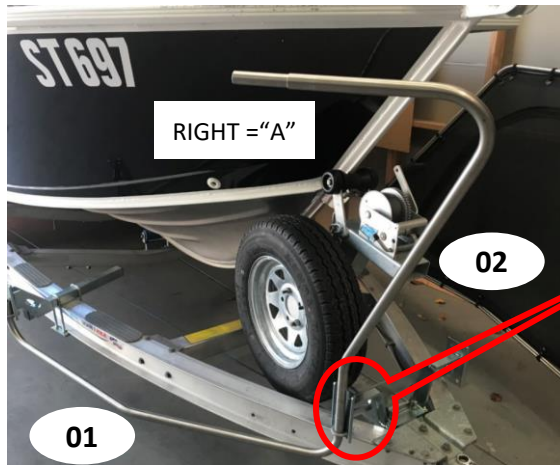

Step 6

Slide the **Upper Rear Tube RH (05)** into the end of the **Front Support Tube RH (02)** using the "A" & "B" labels as a guide.

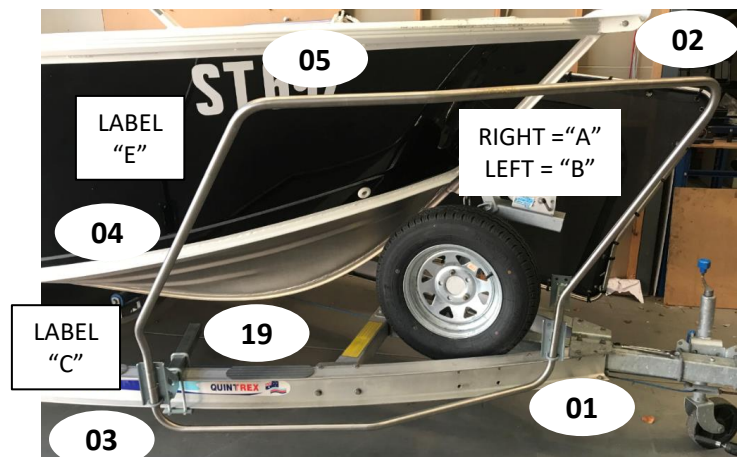

Step 7

Slide the **Rear Mounting Tube (04)** into the **Rear Lower Tube (03)** (LABELS "C") and end of **Upper Rear Tube (05)** (LABELS "E").

Secure **Rear Mounting Tube (03)** to **Rear Mounting Bracket Assy (19)** with a **Small Round U Bolt (17)** M10(25T) x 26(W) x 47(L).

Adjust width of Front Mount Bracket (12) and position of the Rear Mounting Bracket (19) to allow minimum 100mm of clearance between stone guard frame and boat gunnel.

NOTE:- NO PART OF THE STONE GUARD IS ALLOWED TO EXTEND OUTSIDE WIDEST PART OF BOAT OR TRAILER.

Step 8

Attach the **Mesh (23)** using the bungee cords (**23**) on RH and LH side. Recommended sequence for attaching bungee cords uniformly is, first at each corner of frame (**XX**), secondly at each middle section of frame (**YY**) and then remaining portion of frame as per below image.

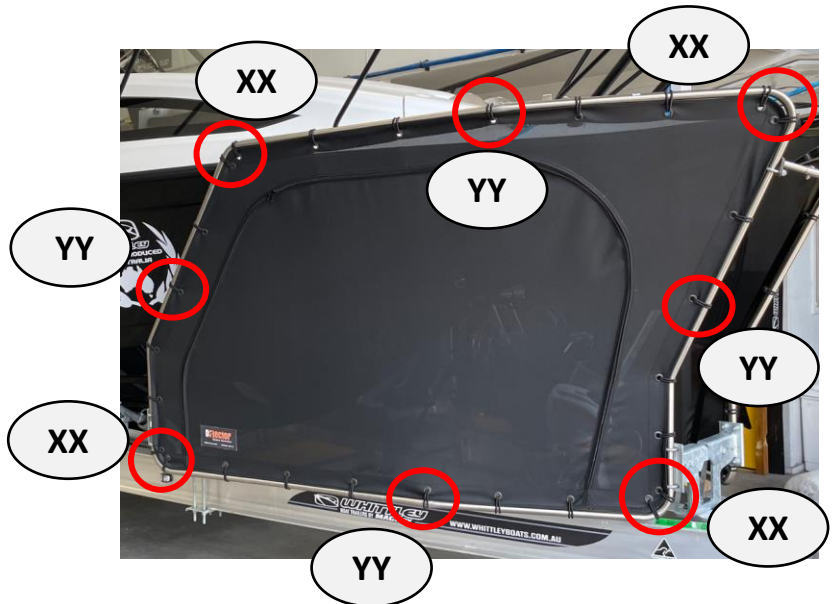

Step 9

Attach the **Front Cross Brace Assembly (13,14)** to the **Front Support Tube RH & LH (02)** using 2 off the **Small Round U Bolts (17) M10(25T) x 26(W) x 47(L)**. Preferred location is approximately middle of top 2 bungee cords position. Adjust the **V-tube Front cross brace (13)** to suit the required gap as per boat width then place the **SS Bolts (18)** into available hole on both side and tightened the **Nylon nut (18)**.

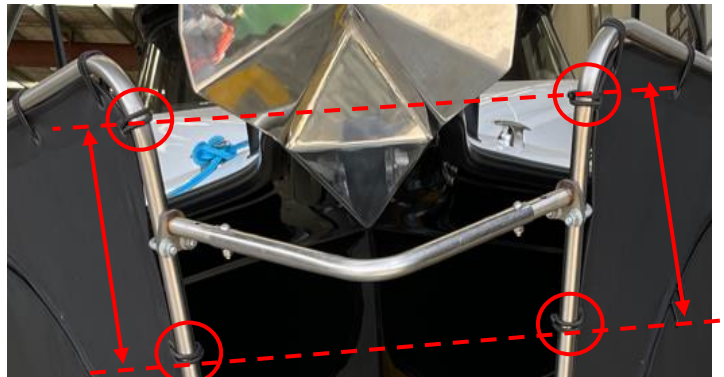
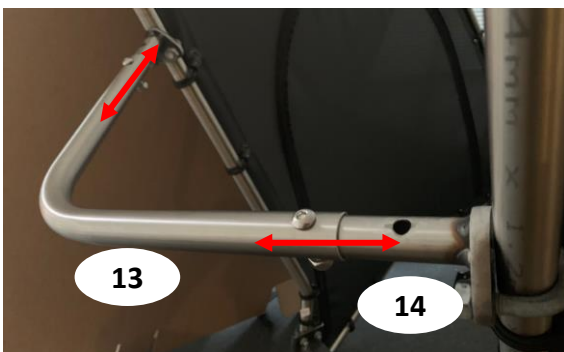

Maxwell and Higgs Pty Ltd provides a three-year warranty from the date of purchase against defects in materials and workmanship. If the product is found to be defective, the product will be repaired or replaced at our discretion. This warranty excludes product alterations, misuse, or improper installation, and does not cover incidental or consequential damages. For warranty service, return the product with proof of purchase to the address listed in this manual.