

D-Flector Stone Guards: Best safety companion for the road untraveled.

You have acquired a D-Flector accessories, **Congratulations**.

D-Flector stone guard provided unparallel protection to your RV, adjustable fittings, remain durable in harshest outback conditions.







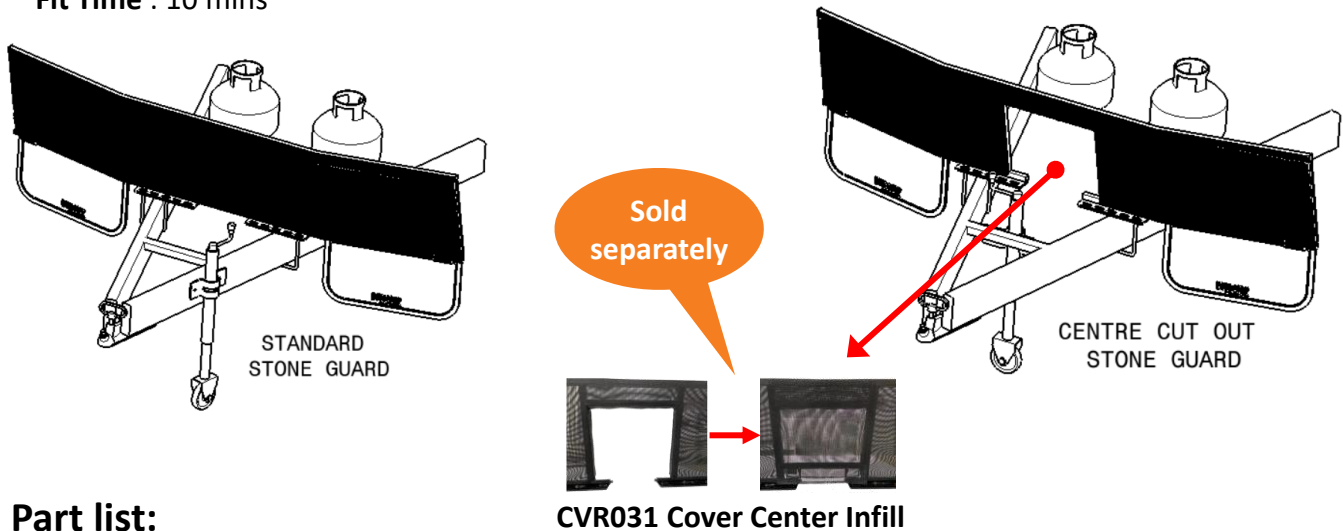

Important:

1. Refer to your fitting instructions to ensure that product is installed correctly.
2. Check the contents of kit before commencing fitment and report any discrepancies.
3. Keep checking D-Flector website to ensure you have latest revisions of these instructions.

Fit Time : 10 mins

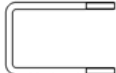

Part list:

Item No	Qty	Part Description	Image	Item No	Qty	Part Description	Image
01	1	Stone Guard Assy		05	4	Reflector screw - M06x16	
02	2	Mudflaps		06	8	Mudflap Screw - M12x25	
03	2	Reflector - white 93X35X7 (7035 Series)		07	8	Mudflap Washer	
04	2	U Bolt M12(50T) x 100(W) x 180(L) - UBT001		08	4 Sets	M12 Fasteners - Nuts, Washer & Spring Washer	



PERIODICALLY CHECK TO ENSURE THAT ALL FASTENERS ARE TIGHT AND ALL STRUCTURAL COMPONENTS ARE SOUND.

Step 1

1. Remove 4 mudflap retaining **self-drilling screws** (06) and **washers** (07) as shown in figure A.
2. Rotate **mudflap** (02) to vertically downward position.
3. Re-install 4 retaining **self-drilling screws** (06) & **washers** (07); and tighten them.
4. Repeat same process for another **Mudflap** (02) also.

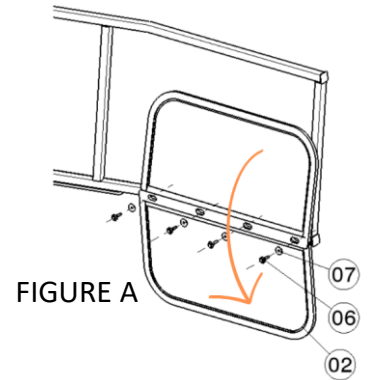

Step 2

1. **Reflectors** (03) are already installed with the **self-locking screws** (05).
2. Locate stone guard centrally symmetric position on "A Frame" or "Draw Bar".
3. See image for Standard Stone guard and Centre Cut Out Stone Guard.
4. Allow sufficient room for rotation of Jockey wheel handle, See FIGURE B.

Warning:- Allow sufficient room for vehicle maneuvering to prevent its contact with stone guard.

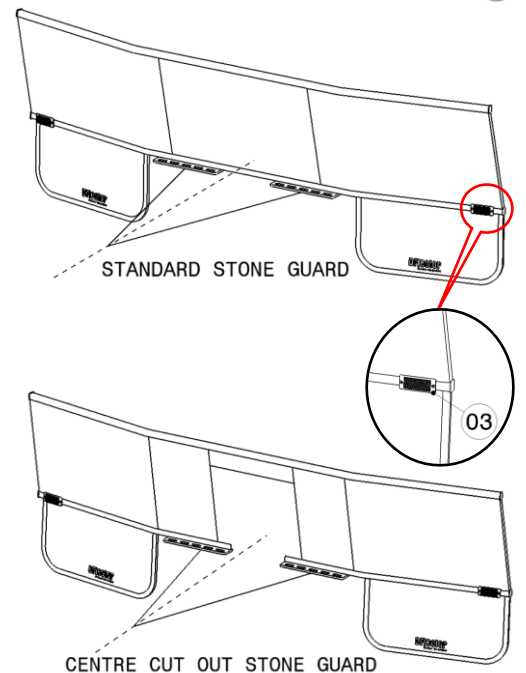
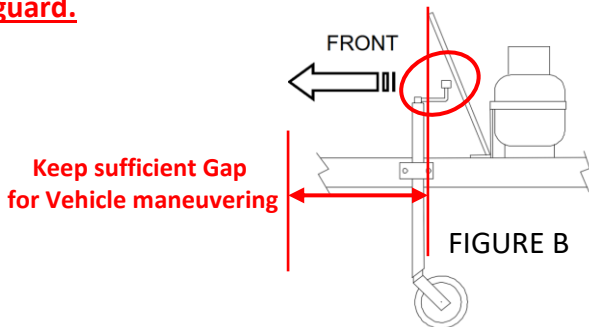

Step 3

1. Place **M12 U Bolt** (04) around chassis or A-Frame RHS.
2. Locate U bolt through suitable slots in **mounting plate** (01).
3. Fasten M12 flat **washer, Spring washer and Nut** (08), onto U Bolt thread..
4. Repeat same process in 3 other places.
5. Tighten all nuts securely.

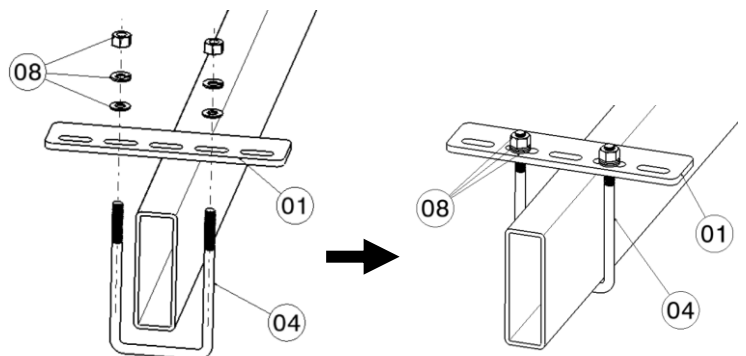

Maxwell and Higgs Pty Ltd provides a three-year warranty from the date of purchase against defects in materials and workmanship. If the product is found to be defective, the product will be repaired or replaced at our discretion. This warranty excludes product alterations, misuse, or improper installation, and does not cover incidental or consequential damages. For warranty service, return the product with proof of purchase to the address listed in this manual.